

Thank you for purchasing this Table Lotus 120'. Please read the instructions carefully before use to ensure safe and satisfactory operation of this product.

---

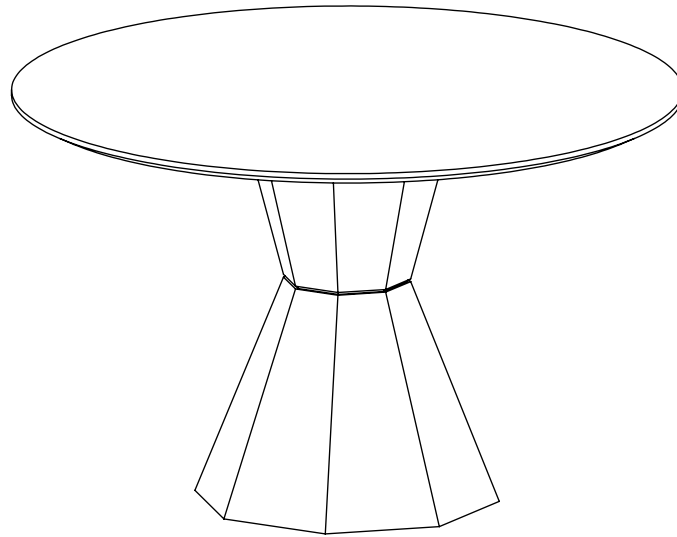

## Pre-assembly preparation

Please ensure instructions are read in full before attempting to assemble this product.

---

### People to assemble



### Tools required

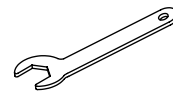

Please check the pack contents before attempting to assemble this product. A full checklist of components is given in this leaflet. If any components are missing, please contact the retailer from whom you bought this product.

This product is **HEAVY**, it should be assembled as near as possible to the point of use. **TAKE CARE WHEN LIFTING** to avoid personal injury and (or) damage to the product.

This product takes approximately **20 MINUTES** to assemble with **2 PERSON**.





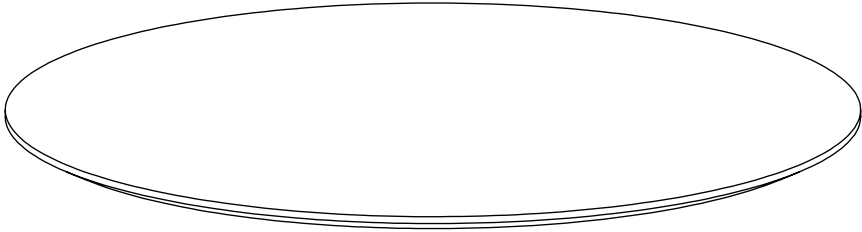
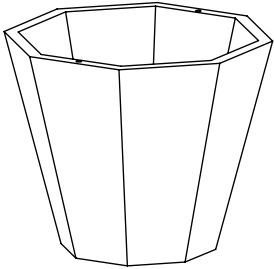
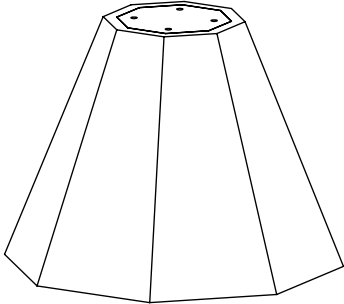
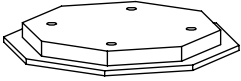

The fittings pack contains **SMALL ITEMS** which should be **KEPT AWAY FROM YOUNG CHILDREN**.

Read this leaflet in full before commencing assembly.

**PLEASE KEEP THESE INSTRUCTIONS FOR FUTURE REFERENCE**

# Fittings and parts checklist

Parts checklist					
A	Table top x1				
B	Upper octagon cone x1		C	Lower octagon cone x1	
D	Middle octagon plate x1				

Fitting checklist					
E	Long thread stud x4 M8x380mm				
F	Wooden dowel x2 Dia8x30mm		G	Spring washer x4 M8	
H	Flat washer x8 M8		I	Hexagon nut x8 M8	
J	Spanner x1				

---

## Step by step assembly instructions

---

### Step One

Insert 4x hexagon nut (part I) onto 4x long thread stud (part E) and screw a little as shown below.

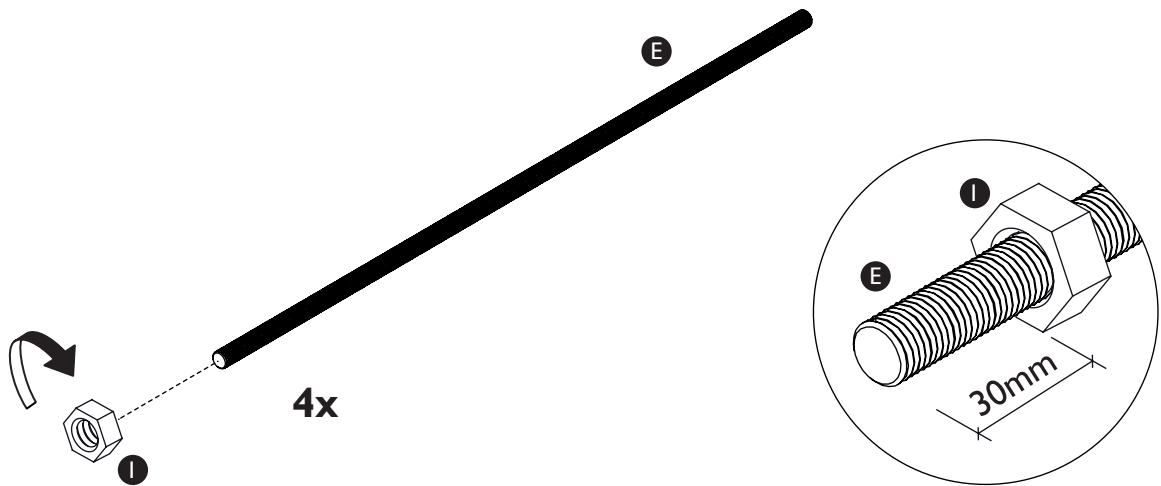

### Step Two

With 2 people, carefully place the table top (part A) upside down onto a soft surface. Insert the flat washer (Part H) then screw the long thread stud (part E) into the fixing point on the underside of the table top (part A) **until finger tight**.

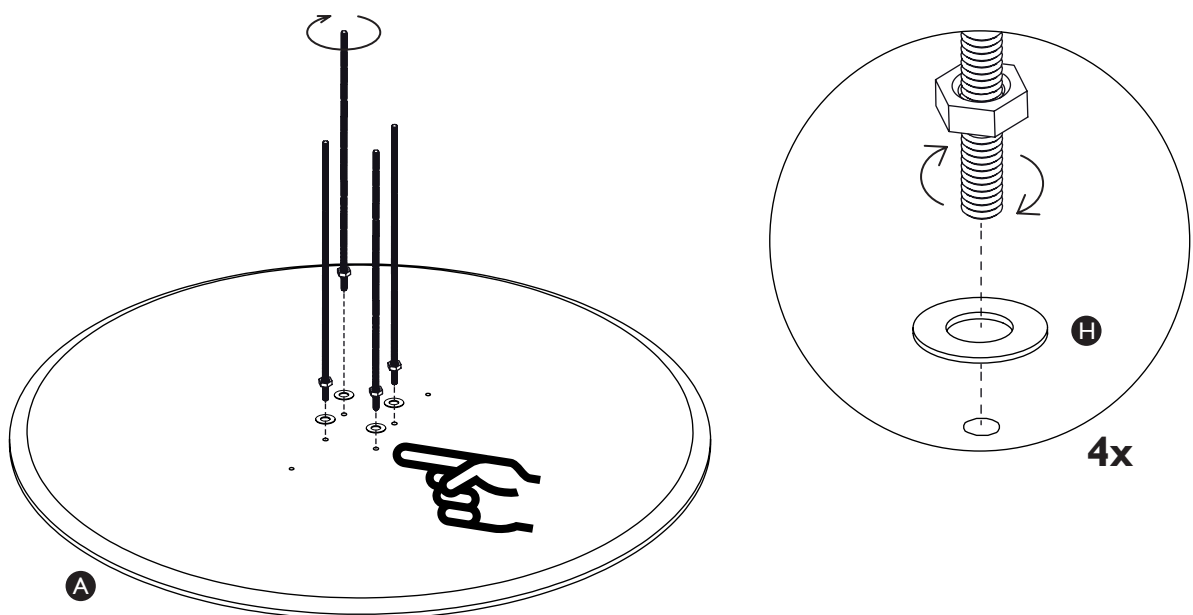

---

## Step by step assembly instructions

---

### Step Three

Using spanner (part J), tighten hexagon nut (part I) in a clockwise direction so that the hexagon nut (part I) and long thread stud (part E) are fixed tightly in place.

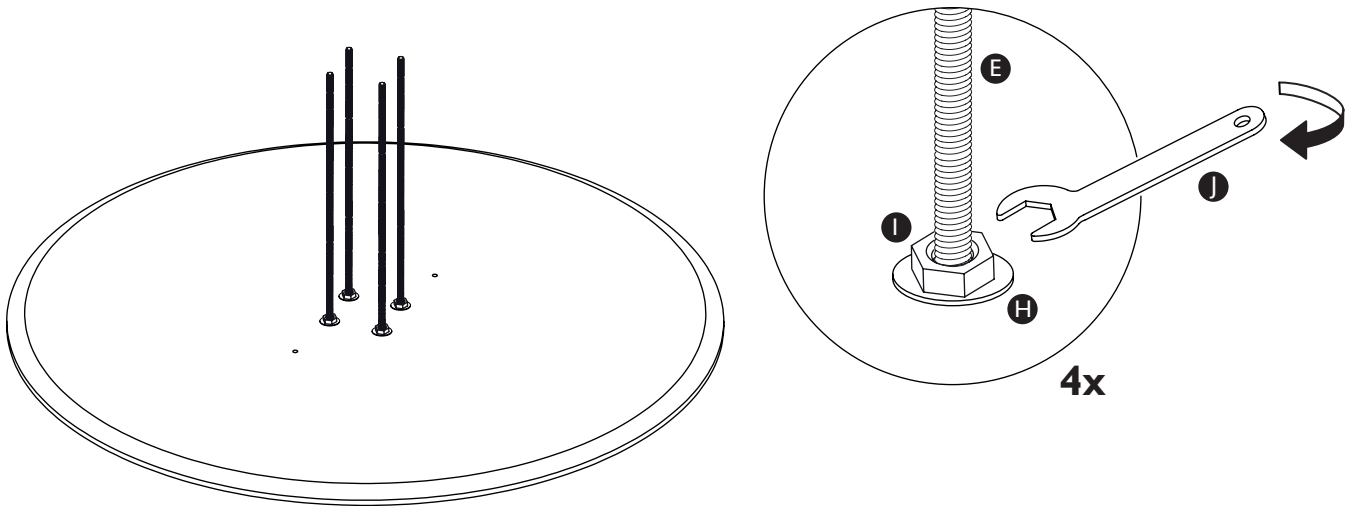

### Step Four

Carefully locate the upper octagon cone (part B) with 2x wood dowels (part F) as shown below.

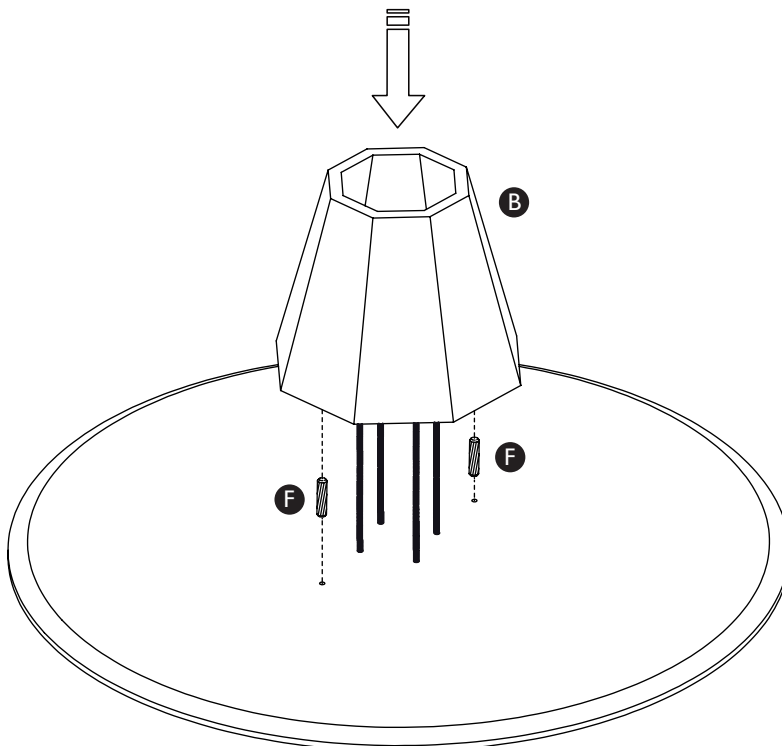

---

## Step by step assembly instructions

---

### Step Five

Insert the middle octagon plate (part D) carefully over the studding (part E) as shown below.

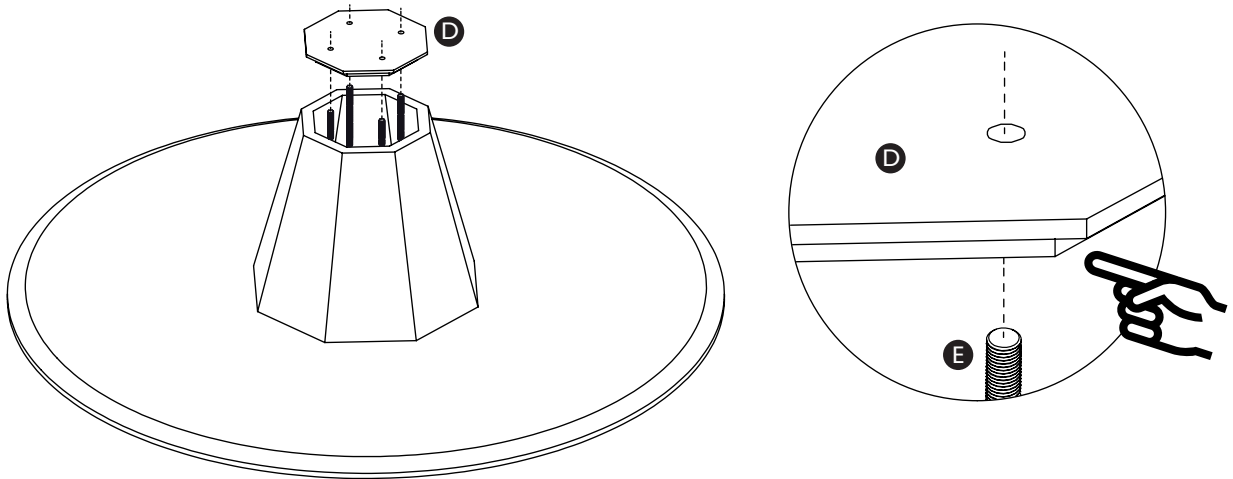

### Step Six

With 2 people, carefully insert the lower octagon cone (part C) over the studding (part E) as shown below.

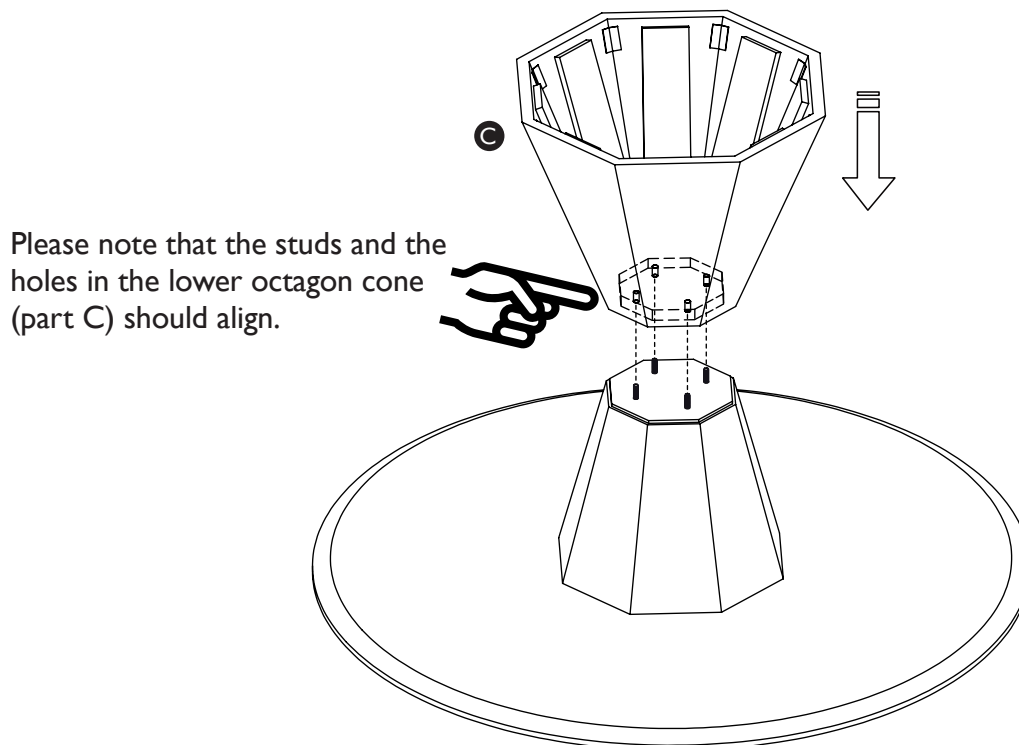

---

## Step by step assembly instructions

---

### Step Seven

Using spanner (part J), tighten hexagon nut (part I) in a clockwise direction with spring washer (part G), flat washer (part H) as shown below.

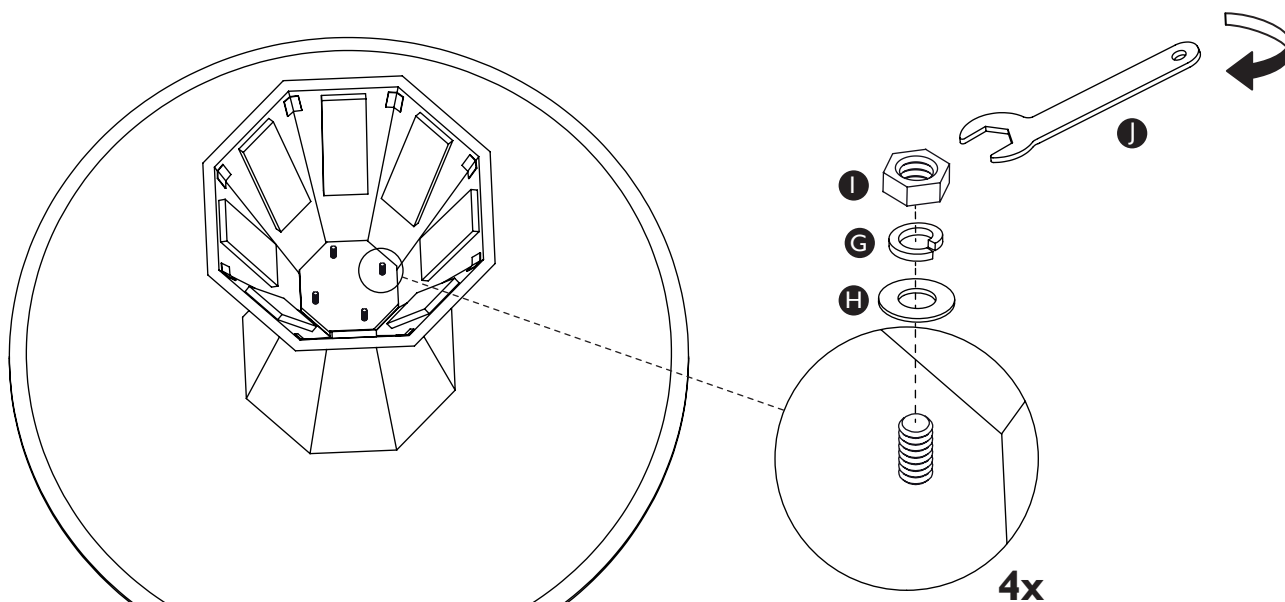

**IMPORTANT:**  
Nut (part I) must be tightened very securely before use.

### Step Eight

With 2 people, carefully turn the table over and place in position.



Heavy

### CAUTION!

Please take care when lifting. Do not drag the table when moving, must be lifted to prevent damaging the pedestal!

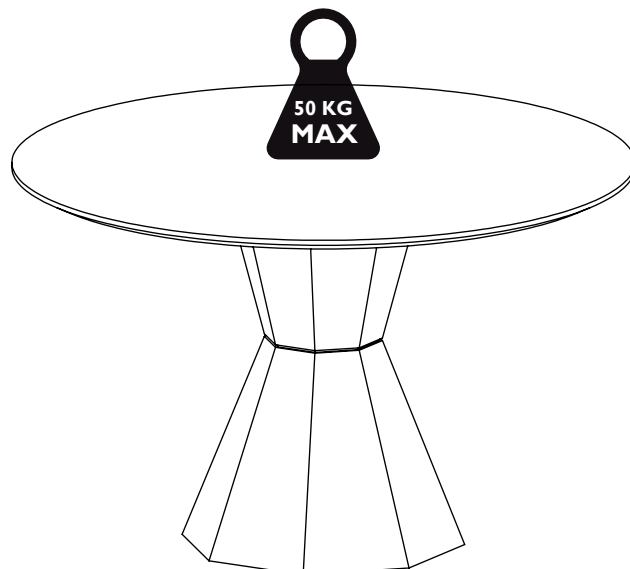
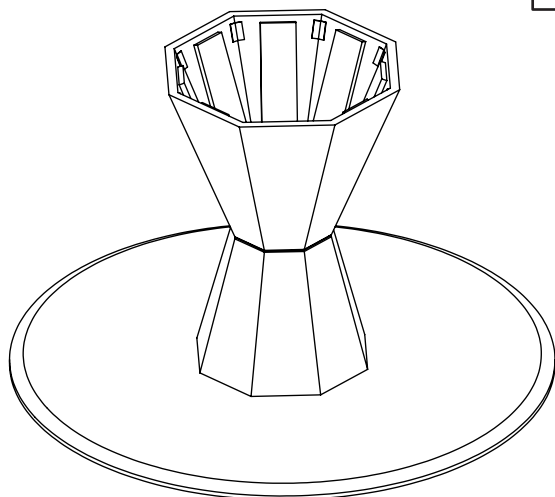

---

## Care and Maintenance

---

### Wood furniture

- Wood displays different grain patterns depending on which way they cut - for example, the 'medullary rays' which can appear as a mark of good quality timber - these are just characteristics of the natural beauty of the wood. Some furniture is also deliberately aged and rustic.
- Wood veneers also allow distinctive patterns to be created on flat surfaces, such as table tops and drawer fronts by the way the slivers are arranged.
- All timber surfaces will change colour and mellow over time. New furniture will initially vary in shade from items that have been previously purchased.

### How to care for your wood furniture

- Furniture with a hard lacquer, wax polish or painted surface should be dusted with a dry cloth.
- Spray polishes are best avoided as they contain silicones which may spoil the furniture's surface by building up over time.
- Make sure all surfaces are protected from heat and liquids by mats and coasters. Wipe up spills immediately and ensure that a mat or pad is placed under paper if you are writing.
- Our furniture will endure most temperatures in the home but it is best to avoid placing furniture next to heat sources such as radiators or fires. Be particularly careful with solid wood as the lack of humidity caused by central heating can cause damage such as warping.

---

## Safety instructions

---

- Never drag furniture when moving it, always lift it.
- Do not sit or stand upon this product.
- Periodically check all fixings to ensure none have come loose and re-tighten where necessary.
- Please take care when handling or moving the furniture, careless handling may cause damage or injury.
- Furniture can be dangerous if incorrectly installed. Assembly should be carried out by a competent person. No liability will be accepted for damage or injury caused by incorrectly installed or assembled furniture.
- It is recommended that before moving heavy objects to a new location they are completely dis-assembled to avoid personal injury or damage to the furniture. Please be careful to retain all fittings when doing this.

### **PLEASE READ!**

**This veneered product top has a natural open grain finish. Please read the care guide thoroughly. We recommend using mats and wiping up spilled liquids immediately. Avoid placing plant pots or vases with out waterproof mats to prolong the life of this product.**

---

## Experiencing problems with your new product?

---

Before calling customer service, please have your item's batch code ready.

You can find the batch code on the back or bottom of your product as below shown.

**(example batch code: I90510)**

