

Fitting Instructions

Please read instructions carefully before fitting the seat, and refer to Care instructions for maintenance.

Place the **Seat Washers** onto the **Hinge Plate**, and insert the **Joining Bolts** through the toilet-pan fixing holes.

Place the **Black Washers** through the **Joining Bolts**, and secure the **Joining Nuts** to the **Joining Bolts**, ensuring a secure final fit to the underside of the toilet-pan. Joining Nuts must be tight otherwise the seat will move around, but do not over tighten as this may damage the toilet-pan; after a few days further tighten nuts to allow for the compression of **Seat Washers** that would have occurred.

Note: For this installation, there is no need to use the seat washer with double holes.

Care Instructions

The toilet seat has been coated with a durable lacquer, but still needs to be treated with care.

- Surfaces should be cleaned regularly with a soft damp cloth and mild soap.
- Do not scrub or use abrasive cleaning materials.
- Do not use bleach or cleaners containing bleach.
- Polishing of the seat surfaces should not be needed, but a wax free polish is advised as this does not smear.
- **IMPORTANT!** Do not stand on the lid or toilet seat; this may cause damage to it.
- As with all toilets seats: If you use bleaches and strong cleaners in the pan, do not leave the seat closed whilst the cleaner acts on the pan– the fumes from bleaches & cleaners may destroy and/or discolour the finish on the seat.

HINGE SET

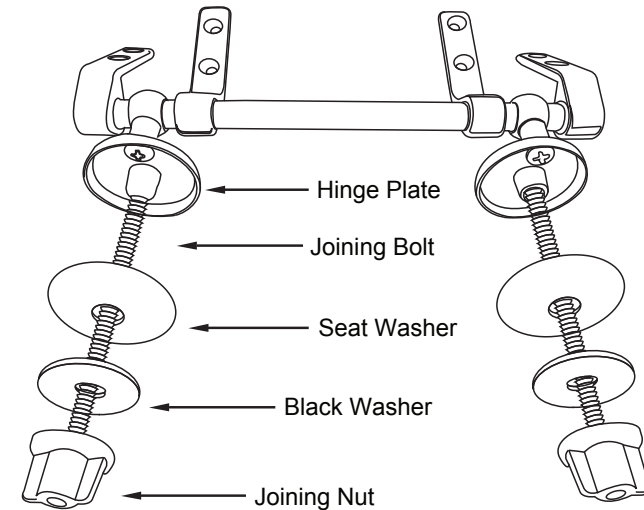

INSTALLATION METHOD

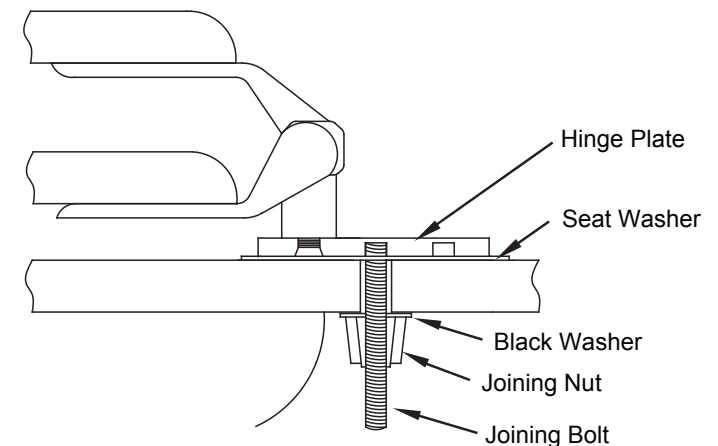



FINISH

Moulded Wooden Seat Bar Hinge & Soft Close Seats.

A sustainable green alternative with better consistency of finish and long term durability.

Moulded with Ash, Eucalyptus, Pine and water-resistant resin which is then veneered at high pressure resulting in an extremely strong moulded wood toilet seat.

The mahogany seat is then flow-coated with a high gloss polyurethane coat while the oak seats are sprayed with a satin polyurethane coating.

All the attributes of a wooden seat, look, feel and individuality, the solid moulded wooden core means the seat cannot crack or split.

CLEANING – for Golden Oak & Mahogony finished seats

DO NOT USE ANY TYPE OF ABRASIVE CLEANER, BLEACH or CLEANERS CONTAINING BLEACH; this will destroy the sealed finish on the seat. Clean with soft damp cloth and mild soap mixture weekly. Polishing the seat should not be needed, but if you do a wax free polish is advised as this does not smear.

As with all toilets seats: If you use bleaches and strong cleaners in the pan
DO NOT LEAVE THE SEAT CLOSED whilst the cleaner acts on the pan
– the fumes from bleaches & cleaners may destroy and/or discolour the finish on the seat.

